



Wkładka dystansowa z wyłożeniem PTFE wg DIN

Wykonanie według DIN 2848 ; DIN 2874
Kołnierze wykonane według DIN EN1092-1 DIN 2848

Wariant 1



Wariant 2

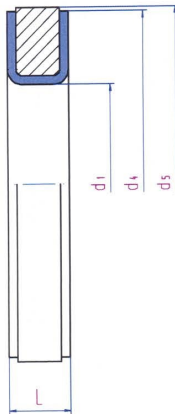

Wariant 3

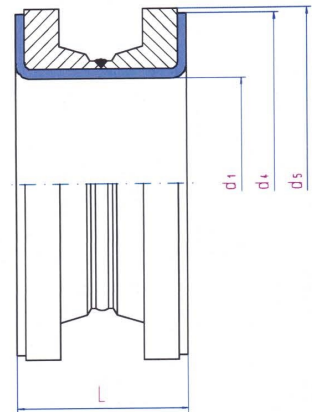

ARMATURA Z WYŁOŻENIEM TEFLOWNYM

Uwagi ogólne: Wszystkie informacje techniczne i porady oparte są o dotychczasowe doświadczenia producenta, nie stanowią jednak żadnej gwarancji z naszej strony. Wartości te muszą być każdorazowo sprawdzone przez naszych klientów, ponieważ tylko oni mogą ocenić działanie medium w rzeczywistych warunkach zastosowania.



Wkładka dystansowa z wyłożeniem PTFE wg DIN PN10 – tabela wymiarowa

DN	d1 [mm]	d4 [mm]	d5 [mm]	b [mm]	Długość całkowita L [mm]																	
					Wariant 1			Wariant 2						Wariant 3								
					10	15	20	20	25	30	40	50	60	70	80	90	60	70	80	90	100	
					Wymiary graniczne									Wymiary graniczne								
15	13	45	50	10	x	x	x	x	x	x	x	x	-	-	-	-	x	x	x	x	-	
20	16	58	60	12	x	x	x	x	x	x	x	x	-	-	-	-	x	x	x	x	-	
25	22	68	70		x	x	x	x	x	x	x	x	-	-	-	-	x	x	x	x	-	
32	31	78	82		x	x	x	x	x	x	x	x	-	-	-	-	x	x	x	x	-	
40	37	88	92		x	x	x	x	x	x	x	x	-	-	-	-	x	x	x	x	-	
50	48	102	107	14	x	x	x	x	x	x	x	x	-	-	-	-	x	x	x	x	-	
65	64	122	127		x	x	x	x	x	x	x	x	-	-	-	-	x	x	x	x	-	
80	76	138	142	16	x	x	x	x	x	x	x	x	-	-	-	-	x	x	x	x	x	
100	101	158	162		x	x	x	x	x	x	x	x	x	-	-	-	-	x	x	x	x	x
125	125	188	192	18	x	x	x	-	x	x	x	x	x	x	-	-	-	-	x	x	x	x
150	153	212	218		x	x	x	-	x	x	x	x	x	x	-	-	-	-	x	x	x	x
200	201	268	273	20	x	x	x	-	x	x	x	x	x	x	-	-	-	-	x	x	x	x
250	254	320	328	22	x	x	x	-	x	x	x	x	x	x	-	-	-	-	x	x	x	x
300	303	370	378		x	x	x	-	x	x	x	x	x	x	-	-	-	-	x	x	x	x
350	333	430	438		x	x	x	-	x	x	x	x	x	x	-	-	-	-	x	x	x	x
400	382	482	488	24	x	x	x	-	x	x	x	x	x	x	-	-	-	-	x	x	x	x
500	480	585	594	26	x	x	x	-	x	x	x	x	x	x	-	-	-	-	x	x	x	x

ARMATURA Z WYŁOŻENIEM TEFLONOWYM

Uwagi ogólne: Wszystkie informacje techniczne i porady oparte są o dotychczasowe doświadczenia producenta, nie stanowią jednak żadnej gwarancji z naszej strony. Wartości te muszą być każdorazowo sprawdzane przez naszych klientów, ponieważ tylko oni mogą ocenić działanie medium w rzeczywistych warunkach zastosowania.



Wkładka dystansowa z wyłożeniem PTFE wg DIN PN25 – tabela wymiarowa

DN	d1 [mm]	d4 [mm]	d5 [mm]	b [mm]	Całkowita długość L [mm]															
					Wariant 1					Wariant 2					Wariant 3					
					10	15	20	20	25	30	40	50	60	70	80	90	60	70	80	90
Wymiary graniczne										Wymiary graniczne										
15																				
20																				
25																				
32																				
40																				
50					Jak dla wartości PN 40															
65																				
80																				
100																				
125																				
150																				
200	201	278	284	26	x	x	x	-	x	x	x	x	x	-	-	-	-	x	x	x
250	254	335	340		x	x	x	-	x	x	x	x	x	x	-	-	-	-	x	x
300	303	395	400	28	x	x	x	-	x	x	x	x	x	-	-	-	-	x	x	x
350	333	450	457	32	x	x	x	-	x	x	x	x	x	-	-	-	-	x	x	x
400	382	505	514	34	x	x	x	-	x	x	x	x	x	x	-	-	-	-	x	x

ARMATURA Z WYŁOŻENIEM TEFLOWNYM

Uwagi ogólne: Wszystkie informacje techniczne i porady oparte są o dotychczasowe doświadczenia producenta, nie stanowią jednak żadnej gwarancji z naszej strony. Wartości te muszą być każdorazowo sprawdzane przez naszych klientów, ponieważ tylko oni mogą ocenić działanie medium w rzeczywistych warunkach zastosowania.



Wkładka dystansowa z wyłożeniem PTFE wg DIN PN40 – tabela wymiarowa

DN	d1 [mm]	d4 [mm]	d5 [mm]	B [mm]	Długość całkowita L [mm]																	
					Wariant 1			Wariant 2						Wariant 3								
					10	15	20	20	25	30	40	50	60	70	80	90	60	70	80	90	100	
					Wymiary graniczne												Wymiary graniczne					
15	13	45	50	12	x	x	x	x	x	x	x	x	-	-	-	-	x	x	x	x	-	
20	16	58	60	14	x	x	x	x	x	x	x	x	-	-	-	-	x	x	x	x	-	
25	22	68	70		x	x	x	x	x	x	x	x	-	-	-	-	x	x	x	x	-	
32	31	78	82		x	x	x	x	x	x	x	x	-	-	-	-	x	x	x	x	-	
40	37	88	92		x	x	x	x	x	x	x	x	-	-	-	-	x	x	x	x	-	
50	48	102	107	16	x	x	x	x	x	x	x	x	-	-	-	-	x	x	x	x	-	
65	64	122	127	18	x	x	x	x	x	x	x	x	-	-	-	-	x	x	x	x	-	
80	76	138	142		x	x	x	x	x	x	x	x	x	-	-	-	-	x	x	x	x	-
100	101	162	168	20	x	x	x	x	x	x	x	x	x	-	-	-	-	x	x	x	x	-
125	125	188	194	22	x	x	x	-	x	x	x	x	x	x	-	-	-	-	x	x	x	-
150	153	218	224	28	x	x	x	-	x	x	x	x	x	x	-	-	-	-	x	x	x	-
200	201	285	290	28	x	x	x	-	x	x	x	x	x	x	-	-	-	-	x	x	x	-
250	254	345	352	30	x	x	x	-	x	x	x	x	x	x	-	-	-	-	x	x	x	-
300	303	410	417	34	x	x	x	-	x	x	x	x	x	x	-	-	-	-	x	x	x	-
350	333	465	474	36	x	x	x	-	x	x	x	x	x	x	-	-	-	-	x	x	x	-
400	382	535	546	42	x	x	x	-	x	x	x	x	x	x	-	-	-	-	x	x	x	-

ARMATURA Z WYŁOŻENIEM TEFLONOWYM

Uwagi ogólne: Wszystkie informacje techniczne i porady oparte są o dotychczasowe doświadczenia producenta, nie stanowią jednak żadnej gwarancji z naszej strony. Wartości te muszą być każdorazowo sprawdzone przez naszych klientów, ponieważ tylko oni mogą ocenić działanie medium w rzeczywistych warunkach zastosowania.



Wkładka dystansowa z wyłożeniem PTFE wg ANSI Class 150

Kołnierze wykonane według ASME B16.5

Wariant 1



Wariant 2

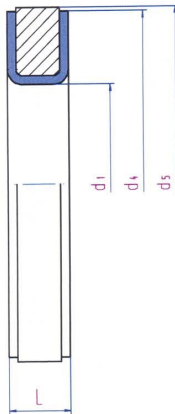

Wariant 3

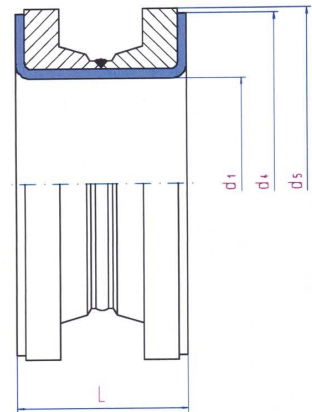

ARMATURA Z WYŁOŻENIEM TEFLONOWYM

Uwagi ogólne: Wszystkie informacje techniczne i porady oparte są o dotychczasowe doświadczenia producenta, nie stanowią jednak żadnej gwarancji z naszej strony. Wartości te muszą być każdorazowo sprawdzone przez naszych klientów, ponieważ tylko oni mogą ocenić działanie medium w rzeczywistych warunkach zastosowania.



Wkładka dystansowa z wyłożeniem PTFE wg ANSI Class 150 – tabela wymiarowa

DN	d1 [mm]	d4 [mm]	d5 [mm]	B [mm]	Długość całkowita L [mm]																		
					Wariant 1			Wariant 2						Wariant 3									
					10	15	20	20	25	30	40	50	60	70	80	90	60	70	80	90	100		
Wymiary graniczne										Wymiary graniczne													
1/2"	10	35	44	10	x	x	x	x	x	x	x	x	-	-	-	-	x	x	x	x	-		
3/4"	15	43	53	12	x	x	x	x	x	x	x	x	-	-	-	-	x	x	x	x	-		
1"	20	51	63		x	x	x	x	x	x	x	x	-	-	-	-	x	x	x	x	-		
1 1/4"	29	64	73		x	x	x	x	x	x	x	x	-	-	-	-	x	x	x	x	-		
1 1/2"	34	73	82		x	x	x	x	x	x	x	x	-	-	-	-	x	x	x	x	-		
2"	44	92	101	14	x	x	x	x	x	x	x	-	-	-	-	x	x	x	x	-			
2 1/2"	55	105	120		x	x	x	x	x	x	x	x	-	-	-	-	x	x	x	x	-		
3"	70	127	133	16	x	x	x	x	x	x	x	x	-	-	-	-	x	x	x	x	-		
4"	93	157	171		x	x	x	x	x	x	x	x	x	-	-	-	-	x	x	x	x	-	
5"	119	186	193	18	x	x	x	-	x	x	x	x	x	x	-	-	-	-	x	x	x	-	
6"	144	216	219		x	x	x	-	x	x	x	x	x	x	x	-	-	-	-	x	x	x	-
8"	193	270	276	20	x	x	x	-	x	x	x	x	x	x	-	-	-	-	x	x	x	-	
10"	242	324	336	22	x	x	x	-	x	x	x	x	x	x	-	-	-	-	x	x	x	-	
12"	290	381	406		x	x	x	-	x	x	x	x	x	x	x	-	-	-	-	x	x	x	-
14"	322	413	447		x	x	x	-	x	x	x	x	x	x	x	-	-	-	-	x	x	x	-
16"	371	470	511	24	x	x	x	-	x	x	x	x	x	x	x	-	-	-	-	x	x	-	
18"	425	533	546	26	x	x	x	-	x	x	x	x	x	x	x	-	-	-	-	x	x	-	
20"	475	585	603		x	x	x	-	x	x	x	x	x	x	x	x	-	-	-	-	x	x	-

ARMATURA Z WYŁOŻENIEM TEFLONOWYM

Uwagi ogólne: Wszystkie informacje techniczne i porady oparte są o dotychczasowe doświadczenia producenta, nie stanowią jednak żadnej gwarancji z naszej strony. Wartości te muszą być każdorazowo sprawdzane przez naszych klientów, ponieważ tylko oni mogą ocenić działanie medium w rzeczywistych warunkach zastosowania.